

D.I. Roof Seamers Roof Seaming Guide

GENERAL This seaming guide is provided by Developmental Industries, Inc./D.I. Roof Seamers as the recommended procedure for seaming of your roof system. This guide is intended to be used with your Installation Guide and your project's erection drawings. You are responsible for proper seaming of the roof in accordance with the erection drawings and this seaming guide, and in accordance with good engineering and construction practices.

SEAMING KIT The seaming equipment will normally be provided as a seaming kit. The seaming kit will consist of the following: (1) **Seaming Kit Shipping/Storage Container** - Contains and protects the seaming tools during shipment and daily storage. (2) **Roof Seamer** - Electric Roof Seamer for forming your roof panel. The machine is specially equipped and setup for your particular roof panel. (3) **Shipping Documents** - Copies of your shipping information and certifications for each piece of equipment in the kit. (4) **Seaming Guide** - A Guide for basic use, operation and troubleshooting. (5) **Hand Crimper(s)** - These ARE NOT automatically included when you order your machine because some builders own their hand crimper(s). (6) **Field Repair Kit** - This kit contains some perishable items that may wear during your use of the machine and the tools to replace them with, if needed. Anything used from this kit must be replaced with the used part. Failure to do so will result in a charge for the missing items.

RECEIVING & SHIPPING Upon receipt of the seaming kit, and before signing the shipping receipt, verify that the seaming kit is received in good condition without damage or loss of contents. If there is damage or loss, immediately file the claim with the shipper and notify D.I. Roof Seamers at 1-888-343-0456. Upon completion of roof seaming, promptly return the seaming kit to: *D.I. Roof Seamers 915 Highway 45 Corinth, MS 38834 USA*

HANDLING & STORAGE Always provide safe and secure handling of the seaming tools when in use. The machine and other parts can cause severe damage and injury if they fall, the machine should be tethered at all times while on the roof. The machine may be too heavy to carry up a ladder. Always hoist the machine onto the roof with proper lifting equipment or with a proper sized rope/tether attached securely to the machine. When starting and finishing the seaming machine at the edges of the roof, the operator and machine must be securely positioned and tethered so the that they can safely lift the machines on and off the seam. When running the machine in the down-slope direction, the machine will have greater inertia and coasting distance. When not locked on the seam, the machine can freely roll on its wheels. Always secure the machine to prevent its rolling or sliding off the roof. At the end of use or when the seaming tools are not in use, the machine must be stored in the seaming kit container, in a safe and dry area. The seaming tools must be cleaned and dried before storing.

ELECTRICAL REQUIREMENTS & SAFETY The seaming machine motor requires a minimum electrical power supply of 20 amp @ 120 Volts @ 60 Hz AC. The electrical service and cords to the seaming machine must be of sufficient capacity to provide the full 20 amp @ 120 Volts *at the seaming machine*. If other tools or equipment are being used on the same service, the service and cord capacity must be increased accordingly. Low voltage due to insufficient cord size or excessive cord length will cause overheating and burnout of the seaming machine's motor.

RECOMMENDED EXTENSION CORD SIZE

Distance (Ft)	0-50	50-100	100-200	200+
Wire Gauge	12	10	8	6

Verify the power cords are fitted with the correct plug for safe and secure electrical connection to the seaming machine. Insure that the power cords are properly grounded and that the service has a ground fault circuit breaker. Insure that the electrical cord is sufficient length to extend the full length of the area to be seamed without stress on the cord or its connections. Insure that the path for the cord is clear and that the cord is clear of snagging on the panel edges or entanglement into the seaming machine rollers. Insure that the cord is seated completely into the machine's power port to prevent a faulty connection and damage to the motor.

INSURANCE You should provide adequate insurance coverage on the seaming tools while they are in your possession and use. No credit will be issued if you lose the machine and you will be fully responsible for any and all rental charges plus the retail value of the Roof Seamer and the Seaming Kit including the case.

SEAM TYPES Your project's design and roof performance requirements govern which seam type is required. Different seam types may be required on specific areas of the same roof. In all cases, refer to the erection drawings to determine the required seam type and location. The 90° Seam requires seaming the roof panel with the 90° Hand Crimper at the eave, ridge end of the roof panel and at the endlaps. Then seaming the full length of the roof panels

with the electric seaming machine. The 180° Seam requires that the roof panel be previously seamed or hand crimped with the 90° Hand Crimper. The starting point must be seamed with the 180° Hand Crimper. Then re-seaming specific areas of the roof with the electric seaming machine.

ROOF PERFORMANCE The roof panels must be correctly seamed before the roof system can provide its designed wind load and weather resistance capability. This means that an un-seamed or improperly seamed roof is subject to wind load failure and/or weather resistance failure. D.I. recommends that you "seam as you go". This means that the roof panels should be seamed as they are installed. This minimizes the opportunity for modulation issues and other common installation problems.

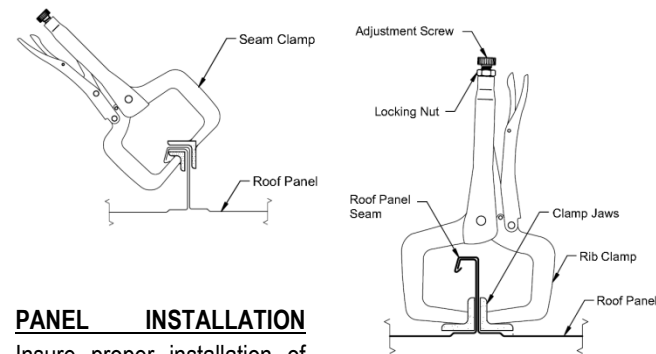

PANEL INSTALLATION

Insure proper installation of your roof panels according to the panel manufacturer's instruction. Poor installation practices can result in faulty seaming. Such faulty seaming can result in seaming difficulty and objectionable seam appearance and in severe cases reduction in roof performance specification. You may use D.I.'s Panel Clamps to assist you in the installation of you panels. Contact us at 1-888-343-0456 or online at www.diroofseamers.com to order.

90° HAND CRIMPING Orient the 90° Hand Crimper onto the roof panel seam as shown. The stationary handle must be in the horizontal position and the operating handle must be rotated up to the open position. When the tool is correctly positioned on the panel, push the stationary handle down solidly against the top of

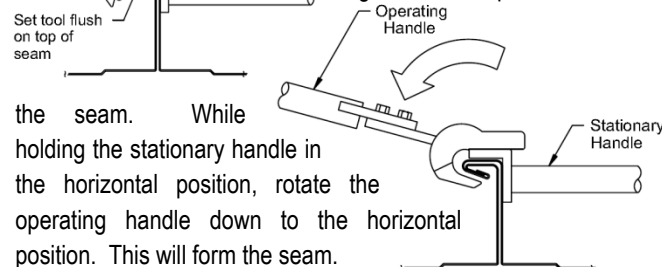

the seam. While holding the stationary handle in the horizontal position, rotate the operating handle down to the horizontal position. This will form the seam. **HAND CRIMPING AT END OF PANEL, ENDLAPS, CLIPS** When hand crimping at the eave or ridge end of the roof panel, the hand crimping must be done in two steps.

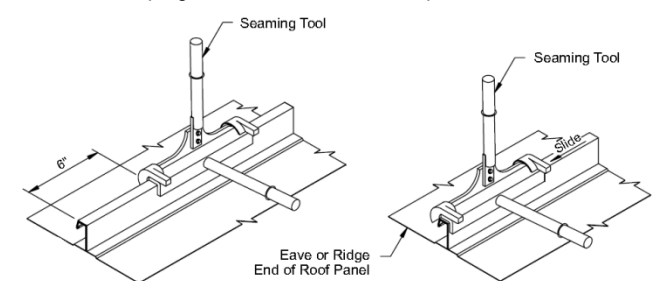

1) Position the end of the 90° Hand Crimper at 6" from the end of the roof panel and hand crimp that area. 2) Position the end of the 90° Hand Crimper flush with the end of the roof panel and hand crimp that area. When hand crimping at a roof panel endlap, the hand crimp must be done in two steps. 1) Center the tool over the

endlap and seam that area. 2) Position the end of the tool 3" uphill from the edge of the endlap and hand crimp that area. This is to allow the uphill sealant to properly flow and allow the electric roof seamer to properly function at the lap.

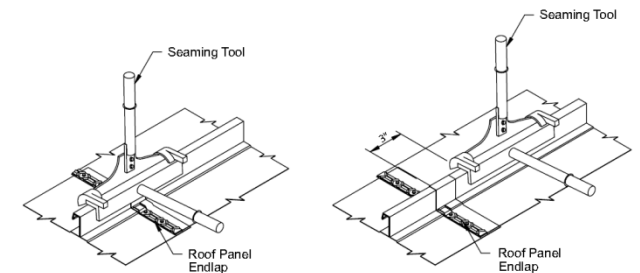

When hand crimping at a panel clip location, center the tool over the panel clip and hand crimp that area.

180° HAND CRIMPING The 180° Hand Crimper is only used at the start location on each seam before the seaming machine is applied. Before using this hand crimper, the area must be 90° hand crimped first. You will only use this hand crimper once, the length of the jaw, set flush with the end of the roof panel. To begin, simply spread the handles open to forming jaw. Place the hand crimper on the seam as shown, holding the handles in a "V" shape. Insure that the notch captures the forming side of the seam and sets properly over the seam. Press down firmly and equally on both handles, spreading them apart. This will form the seam.

CHECKING THE FINISHED SEAM Rotate the operating handle to the open position, remove the tool and check that the seam is correctly formed. If the hand crimper does not correctly form the seam, DO NOT continue seaming and contact D.I. Roof Seamers Technical Support at 1-888-343-0456.

ROOF SEAMER DIRECTION The direction of the seaming machine will be noted near the power switch or on the motor. Note the seaming direction BEFORE attempting to use the tool.

MACHINE POSITION ON THE ROOF PANEL With the locking handle held up in the open position, set the seaming machine onto the starting end of the roof panel's seam over the hand crimped portion of the seam. Roll the seaming machine forward to align the front tooling over the un-seamed portion of the seam. When the machine is in the correct position on the seam, pull the locking handle out to the locked position. The locking handle should lock with minimal resistance when force is applied. If the locking handle will not readily lock, roll the machine forward or

backward slightly until a position is found where the locking handle will readily lock. If the locking handle still does not lock, check the hand crimping to be sure it is in proper form. Once the locking handle is locked, check that the machine's tooling is properly engaged.

CLEAN THE SEAMS The roof panel must be thoroughly cleaned of abrasive dirt or dust that can cause scuffing or scratching of the seam surface. The roof panel seams must be cleaned of grease or other contaminants which can cause seaming machine slippage and marking of the seam surface.

RUNNING THE SEAMING MACHINE Check that the machine's path is clear of power cords, tools, debris, tether lines, etc. Start the machine by turning on the machine's toggle switch. Watch the machine and finished seam carefully for any indications of machine malfunction or faulty seaming. **Caution:** The seaming machine must always be in the vertical position while seaming. Do not allow the machine to tilt sideways when locking the machine onto the seam or while the machine is running. On roofs with high stand-off clips, walking or standing on the panel next to the machine can deflect the panel and cause the machine to tilt. Do not walk or stand on the panel next to the machine while it is running.

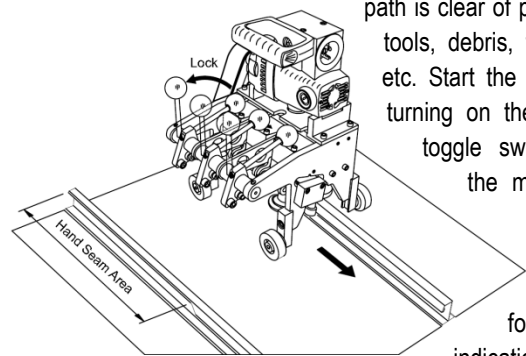

STOPPING THE MACHINE Stop the machine by turning off the machine's toggle switch. Always allow sufficient space for the machine to coast after turning the machine off. Do not run the machine into previously installed end dams or other obstructions. **Note:** The 180° Seam will stop just short of the installed end dams approximately 12". The seam should already be 90° hand crimped at the ridge prior to installation of the end dams. The end dams are designed for 90° Seams only. This does not affect the performance of the roof system. **Caution:** Stop the machine immediately and investigate any indication of machine malfunction or faulty seaming. If the machine does not correctly form the seam, DO NOT continue seaming and contact D.I. Roof Seamers Technical Support at 1-888-343-0456.

UN-LOCKING THE MACHINE After the machine is turned off and has fully stopped, lift up the locking handle to the open position to un-lock the machine from the seam. Using the lift handle, the machine can be lifted from the seam. If the machine must be stopped and removed before completing the seam, use a felt marker to mark the position of the machine's front wheel on the

panel. The machine can later be repositioned on the mark to complete the seaming.

panel. The machine can later be repositioned on the mark to complete the seaming.

CHECKING THE FINISHED SEAM At the completion of each seam, check the full length of the seam for any indications of faulty seaming. The seaming operation exerts high pressure bending forces on the seam. Under such conditions, minor burnishing, pressure marks and dark marking of the seam surface is normal and acceptable. Many markings may be removed with mild cleaning solutions or solvents.

"FLIP FLOP"

MACHINE NOMENCLATURE

The following information identifies the operational parts of the "Flip Flop" seaming machine.

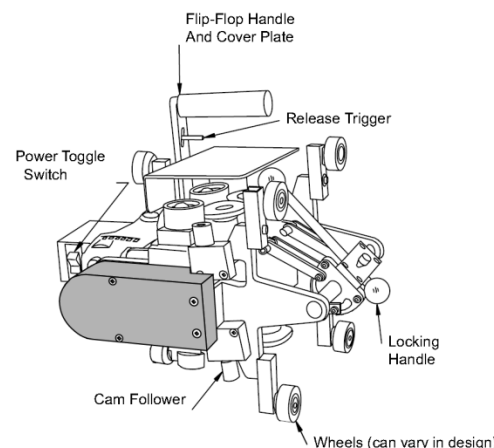

DIFFERENCE IN SEAMING DIRECTION This machine is a very unique labor saving machine because it can form bi-directionally or can be two machines in one. The 90°/90° machine can be run, then "flipped" to run on the adjacent seam to save "drag back" time. The 90°/180° machine can be run as 90° Seam then be "flipped" to run in the opposite direction on the same seam to form 180° Seam.

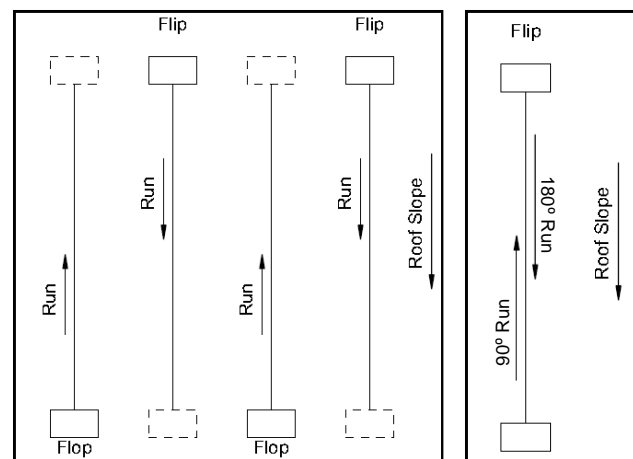

LOCKING THE MACHINE ON THE SEAM When the machine is in the correct position on the seam, pull the locking handle out to the locked position. The locking handle should lock with minimal resistance when force applied. If the locking handle will not readily lock, roll the machine forward or backward slightly until a position is found where the locking handle will readily lock. If the locking

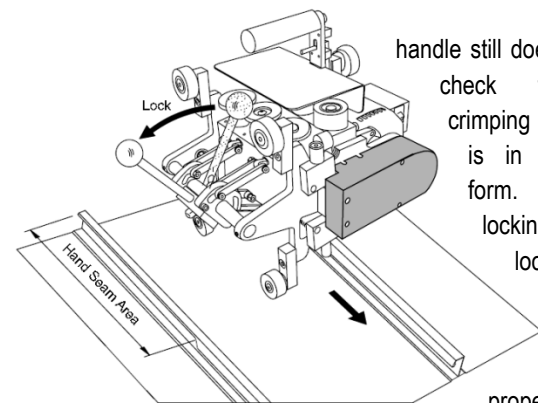

handle still does not work, check the hand crimping to be sure it is in the proper form. Once the locking handle is locked, check that the forming rolls are properly aligned.

STARTING THE SEAMING PROCESS The basic seaming process of starting, running and stopping the "Flip Flop" machine is the same as described previously in this guide. Follow the same basic safety tips such as use of tether lines, stopping the machine near the eave and ridge, unlocking the machine, etc. **Note:** The 180° Seam will stop just short of the installed end dams approximately 12". The seam should already be 90° hand crimped at the ridge prior to installation of the end dams. The end dams are designed for 90° Seams only.

FLIPPING THE "FLIP FLOP" MACHINE Flipping the machine to change the seaming direction is a three step process. The machine will need to be held aloft during this process in order to not damage the panel finish.

Step 1: Using your index finger, lift up on the release trigger until you hear or feel the top plate disengage.

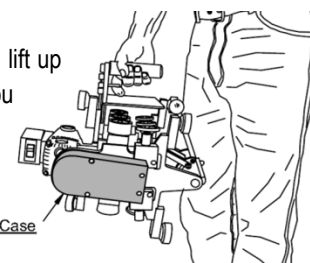

Step 2:

While still holding the seamer aloft, use your free hand to rotate the forming rollers to the next stage.



Step 3: Continue to rotate the unit until the release trigger re-engages and is stabilized with a clicking sound. The unit is now ready to be set onto the next work area.

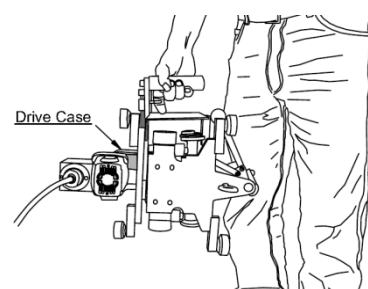

SEAMING MACHINE MAINTENANCE The seaming machine is a precision fabricated, high performance, portable roll forming machine. This relatively lightweight machine does the tough job of forming the extra strong 90° and 180° Seam finished seam under often rugged field conditions. Although designed for tough industrial use, the seaming machine requires proper maintenance to assure proper seaming and efficient, trouble free operation. **Caution:** Failure to properly maintain the seaming machine as instructed below can result in faulty or damaged seams and costly break-down of the seaming machine.

FORMING ROLLERS The forming rollers require the following regular maintenance: (A) Assure that the forming rollers are free of dirt, grease, sealant/mastic, etc. (B) Spray the forming rollers with WD-40 (or equal). (C) Assure that the forming rollers are tight on their shafts. Check and tighten the roller's retainer screws as necessary. (D) On painted roofs, especially during very hot or abrasive conditions, spraying or misting the seams with water, or a light lubricant such as WD-40, ahead of the seaming machine may significantly reduce burnishing and forming marking of the seam surface. (E) On very dry Galvalume roofs, spraying or misting the seams with water, or a light lubricant such as WD-40, ahead of the seaming machine may significantly reduce seaming friction and Galvalume build-up on the forming rollers. (F) When 180° Seaming, the increased seaming pressures may require spraying or misting the seams with water, or a light lubricant such as WD-40, ahead of the seaming machine, significantly reducing burnishing and forming marks of the seam surface.

COOLING VENTS To prevent motor overheating, the motor has vents and an internal fan to provide cooling air flow over the internal motor parts. Check frequently to assure that these vents are kept clean and clear of debris, etc. While the machine is running, never cover the machine or place it in a position where the cooling air flow to the vents will be restricted.

OUR METER Your roof seamer may be equipped with an hour meter near the machine's power port. This is used by D.I. Roof Seamers to track the maintenance of the machine. This meter will only run when the power switch is in the "ON" position. DO NOT attempt to alter or otherwise tamper with this meter. Evidence of this will result in additional charges. If the meter displays anything other than normal numeric values, please refer to the ELECTRICAL REQUIREMENTS & SAFETY section of this guide to insure proper power supply and contact D.I. Roof Seamers Technical Support at 1-888-343-0456 for instructions.

For more information, instructional videos and much more, visit www.diroofseamers.com or call 1-888-343-0456.

D.I. Roof Seamers Roof Seaming Guide