

READ ME FIRST!



D.I. Roof Seamers



Your Contractor Series Roof Seamer motor requires a 20 amp, 100-125 volt AC power supply. Poor performance and motor damage can result from use of an improper power supply.

CONTRACTOR SERIES

3 Station Bi-Directional

ROOF SEAMER

OWNER'S MANUAL

Recommended extension cord size:

Distance (FT)	0-50	50-100	100-200	200+
Wire Gauge (AWG)	12	10	8	6

**READ THIS FIELD MANUAL COMPLETELY
BEFORE ANY SEAMING OPERATIONS!
DEATH OR SERIOUS INJURY MAY OCCUR!**

IMPORTANT INFORMATION

- This Roof Seamer has been setup for your custom panel profile. Never use this machine on any other roof panel or profile. . Never use this machine on any other roof panel or profile and do not use on any material thicker the 24 gauge steel. Do not attempt to alter or modify the machine in any way.
- Follow all safety suggestions and warnings in this manual and posted on the machine itself. Failure to do so may result in serious injury or death.
- Do not attempt to ride the Roof Seamer in any way.
- Your machine comes with a 30 day Manufacturer's Warranty. To purchase an Extended Warranty or to find additional information, visit at www.diroofseamers.com

Before beginning, ensure that the panels are installed correctly and is free of all debris and contaminants such as sand, snow, excessive fluids, sealant/mastic, tools, extensions cords, etc... Also, always attach a safety hook to a tether during any time the seamer is on the roof to prevent it from falling off.

It is recommended to “seam as you go”. In other words, seam the roof panels as they are being installed. This ensures that each panel is kept within module and installed correctly.

Next, place the machine on the hand crimped portion and engage the locking handle by pulling the locking handle out until it locks into place. Connect the power supply into the quick-release plug near the handle of the machine and turn the machine on. Run the seamer for about 12” to ensure that you are receiving the desired seaming operation. If so, continue in this manner for the completion of the run. If not, check the Troubleshooting Guide in on the last page of the manual for help.



This is a BI-DIRECTIONAL Roof Seamer. Therefore, you may simply place the seamer on the next seam and, after hand crimping, run the machine in the opposite direction of travel. It is important to remember to use extreme caution when reaching the edge of the roof. Stop and disengage the locking handle of the seamer while the wheels remain on the roof panel.

Do not run the seamer within 6” of the end of a panel, beyond the end of a panel or over a previously seamed area.

If the roof has already been installed, each clip must be hand crimped with a 90° (Single Lock) Hand Crimper to keep each panel safely in place. (See diagram on next page)

To begin, hand crimp 8"-10" of each panel at the beginning of the seam with the 90° (Single Lock) Hand Crimpers.

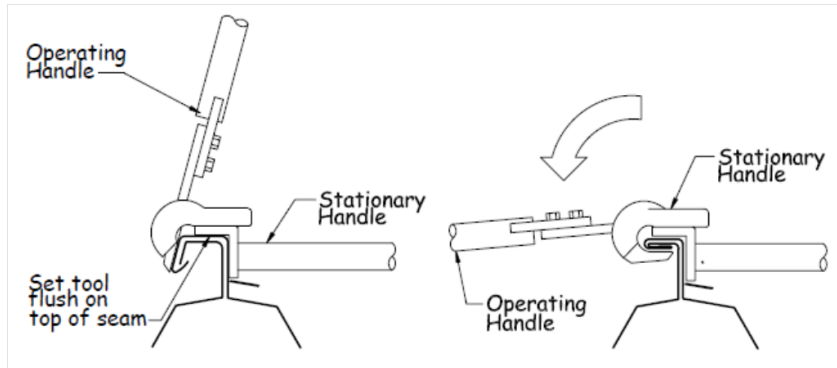

Use your hand crimpers to finish any area that the seamer may not be able to complete, such as against a ridge cap, end cap or at a pitch change in the roof.

Note: The Roof Seamer may leave dark forming marks on light colored panels. This is acceptable as long as the paint finish is not damaged. Marks can easily be rubbed off by hand – DO NOT use solvents that will soften or remove paint.

MAINTENANCE SUGGESTIONS

- Clean tooling DAILY with Mineral Spirits, or as needed due to contaminants.
- If you must remove or replace tooling, place ONE DROP of Loctite® 222 (purple) on the threads of the bolt before putting it back into the machine to prevent the bolts from backing out.
- When not in use, always store your Roof Seamer in a dry place to prevent damage to the machine. NEVER operate it in inclement weather such as rain or snow.

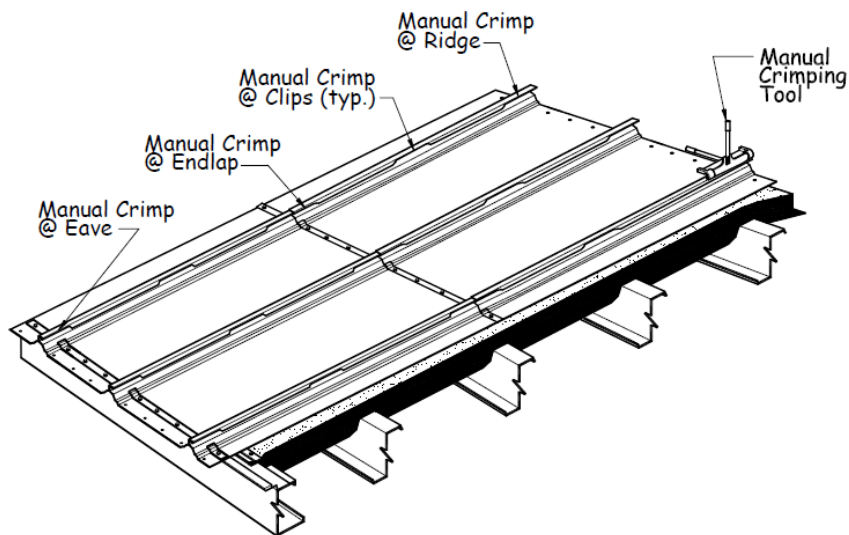

In the event of any problem, contact Technical Support at

1-888-343-0456

Monday – Friday 8:00am – 5:00pm CST

Copyright ©2010 Developmental Industries, Inc.

ROOF SEAMER ACCESSORIES

available for purchase at www.diroofseamers.com!



90° Hand Crimpers \$225

Part #70001



180° HAND CRIMPERS \$225

Part #70007

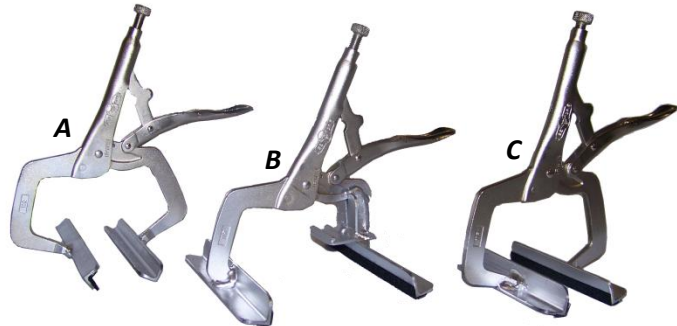

A – Universal Seam Clamp \$24 Part #70502

B – Rib Clamp for 3” Seam (Trapezoidal Panel) \$38 Part #70501

C – Mod. Clamp for 2” Seam (Architectural Panel) \$24 Part #70503

Seaming Problem	Possible Cause	Look For	Recommended Fix
Roof Seamer dragging, stalling at clips, running intermittently or will not run.	Extension cord too long and/or not heavy enough gauge cord.	7+ amp at motor with NO LOAD (locking handle locked). 10+ amp at motor while seaming (between clips).	Use a shorter and/or heavier gauge extension cord.
	Generator not supplying proper amperage to Roof Seamer.	7+ amp at motor with NO LOAD (locking handle locked). 10+ amp at motor while seaming (between clips).	Use a larger generator.
	Faulty Motor.	7+ amp at motor with NO LOAD (locking handle locked). 10+ amp at motor while seaming (between clips). Motor will not run.	Contact D.I. Roof Seamers for replacement unit.
Seam not closed properly or improper nesting of male leg to female leg and/or clip.	Excess panel coverage width (typically 1/2"+).	Cladding or paint deposit on forming roller.	Ensure correct coverage width at installation.
	Incorrect profile of damaged (deformed) clip or male/female panel leg.	Seam does not appear to be fully engaged.	Correct the profile of the male/female panel leg. If necessary, hand crimp the corrected area.
Creasing, scuffing, etched line along top of the seam and/or deformation of seam.	Cam roller does not turn freely.	Cam roller bearing frozen or fouled by sealant or mastic.	Clean and lubricate or replace cam roller.
Cladding or paint pick-off.	Incorrect profile or damaged (deformed) clip or male/female panel leg.	Seam does not appear to be fully engaged.	Correct the profile of the male/female panel leg. If necessary, hand crimp the corrected area.
	Excess panel coverage width (typically 1/2"+).	Cladding or paint deposit on forming roller.	Ensure correct coverage width at installation.

WE HAVE ROOF REMOVAL TOOLS AVAILABLE!